

Hardware Design for Capacitive Touch

AN0040 - Application Note

Introduction

This application note covers the basics of hardware design for capacitive touch sensing with the EFM32 microcontrollers. Both simple touch buttons and more advanced sliders and touch matrices are described, along with key pointers of how to achieve the best possible capacitive touch performance with the EFM32. For the lowest energy consumption and "wake on touch" functionality, an EFM32 with LESENSE should be used.

This application note focuses on how to design hardware for capacitive touch with the EFM32 microcontroller. For code examples, please refer to the capacitive touch software application note (AN0028).

This application note includes:

- This PDF document
- Zip-file with schematic and gerber files for a capacitive touch example board.

1 Introduction

Capacitive sensing is a technology now widespread across different industries. High performance capacitive sensors are capable of high resolution measurements of proximity, position, humidity, fluid levels or acceleration of a conductive target. Lower cost capacitive touch sensors are less advanced and mostly used for human-device interfaces by measuring the capacitance change when a user's finger is nearby. These kind of sensors are increasingly common in devices with a human interface of all sorts.

This application note will focus on sensors used to interface with human users in applications focused on very low power. Low power capacitive touch with the EFM32 can be implemented at low cost and bring many advantages over mechanical switches. They have no moving parts which gives less degradation over time, with usage and with environmental changes. The EFM32 capacitive touch feature is primarily made for implementing capacitive touch buttons and sliders with very low energy consumption, but it can also be adapted to other capacitive sensing applications.

All EFM32's with analog comparator(s) are capable of capacitive touch. For the absolute lowest energy consumption, EFM32's with LESENSE (Low Energy Sensor Interface) can use this peripheral to scan several touch pads continuously and only wake the CPU when a touch is detected.

Regardless of which EFM32 is used for capacitive touch sensing, the design of printed circuit boards or similar hardware for capacitive touch sensing follows the same guidelines which are explained further in this document.

2 Capacitive Sensing Basics

Figure 2.1. Capacitive Sense Overview

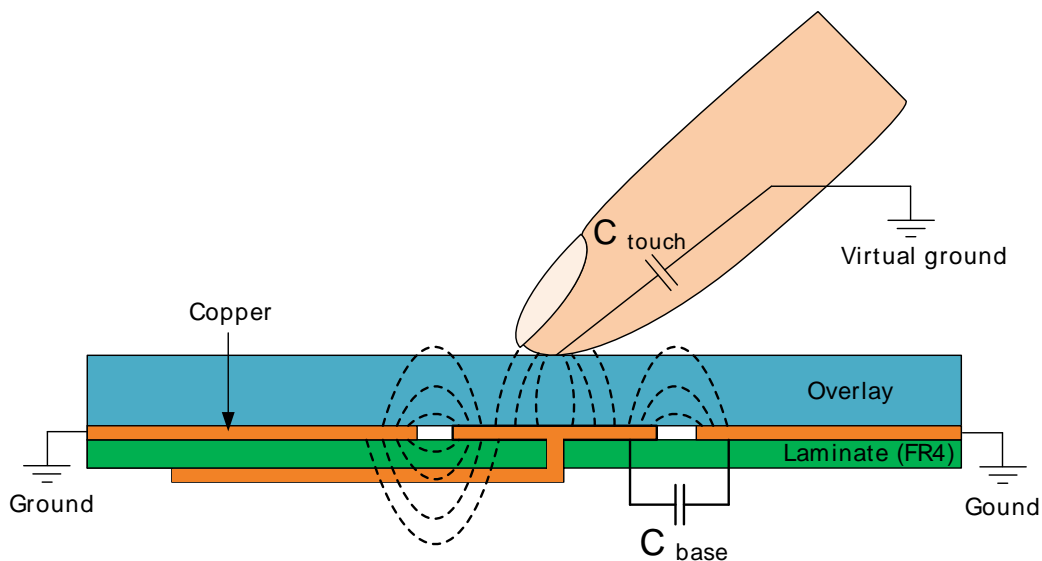

2.1 Working Principle

The working principle of a capacitive touch (or proximity) sensor is to measure the change in capacitance of a given, and otherwise constant, capacitance when approached or touched by a larger body such as a human finger or hand. The capacitive touch pad can be implemented with different technologies, ranging from a trace on a printed circuit board to various conductive coated surfaces like glass or plastic. The PCB approach is often combined with an overlay or cover panel, typically made of some kind of plastic or glass.

When implementing a capacitive touch sensor there are a few possible configurations which can be categorized in two different types; self- and mutual-capacitance. The difference is between which two nodes the capacitance is measured. It can either be between the touch pad and another electrode with different potential than ground, which is the mutual-capacitance type of setup. Or it can be between the touch pad and ground, which is the self-capacitance type of setup. The EFM32 is designed for self-capacitance measurements where the change in capacitance between a touch-pad and ground is the measured entity.

The EFM32s way of measuring changes in capacitance is by using the analog comparator to set up an RC relaxation oscillator. The oscillating circuit includes the capacitance between the touch-pad and ground as the capacitive element. The implementation can be seen in Figure 2.2 (p. 4). By counting the number of oscillations during a fixed time interval, an indication of the capacitance in the RC circuit is acquired. This count value can be compared against a threshold value to determine if a sensor is touched or not because a change in count value indicates a change in capacitance.

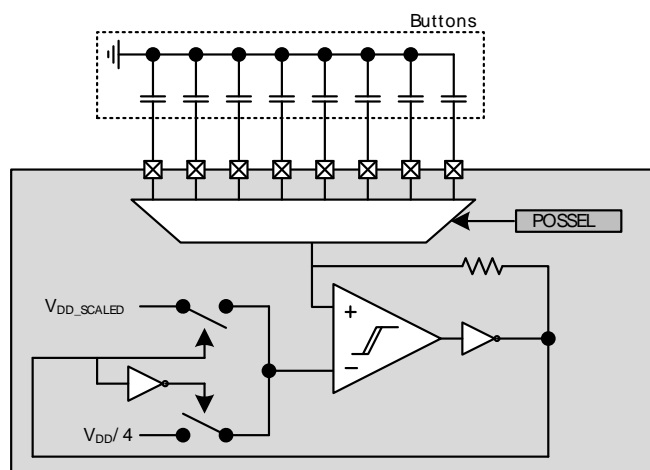
Figure 2.2. Analog comparator RC relaxation oscillator

The quality of a touch measurement is correlated with how much the capacitance between the pad and ground changes upon human touch. This can be directly translated to how large the observed change in count value is when a human finger touches the pad compared to the non-touched count value. The goal of hardware design for capacitive touch is to maximize this change when a human finger touches a pad as well as minimize sources of noise.

Figure 2.1 (p. 3) illustrates a typical capacitive touch button with a finger approaching. The term "virtual ground" refers to the fact that a finger placed close to the capacitive touch pad acts as an electrical body which has a finite impedance to the capacitive touch circuit's own ground.

The typical parameters of the RC oscillator and the capacitance of a pad is listed below.

- Frequency: 100 kHz - 1.5 MHz
- Capacitance of pad: 5 pF - 15 pF
- Change in capacitance upon touch: 0.3% - 50%
- Typical measurement window: 0.2ms - 4ms

2.2 Signal-to-Noise Ratio

The change in capacitance when a finger is placed near the sensor element is generally very small. This means that noise in the measurements needs to be kept even smaller to be able to reliably differentiate between actual touches and noise. The signal-to-noise ratio (abbreviated SNR) is a way to quantitatively compare the performance of different solutions, both hardware- and software-wise.

The SNR definition used in this application note is the same as for the capacitive touch software application note (AN0028). Any definition of SNR could in principle be used to compare different hardware designs. The one chosen here is based on the measurement principle that is used by the EFM32.

A given capacitance between the pad and ground is represented by a count value as described in Section 2.1 (p. 3). The "signal" refers to the difference between the average count for touch and no touch. The ratio between this difference and the noise for an untouched button is the SNR. See Figure 2.3 (p. 5) for an example of SNR. As illustrated the target is to keep the SNR higher than 5.

The term "noise" as used in this document refers to the absolute peak to peak difference observed in the count values for otherwise static conditions. This is a useful definition since the statistical distribution is unknown and less frequently occurring peak values should be taken into account because they can look like false touches.

Note

As a rule of thumb, the SNR should be above 5.

When developing a capacitive touch application one should check that the SNR criterion is fulfilled for the actual PCB with the final overlay (same material and thickness that will be used). For evaluation of the SNR the reader is referred to the capacitive touch software application note (AN0028).

Figure 2.3. Signal to noise ratio

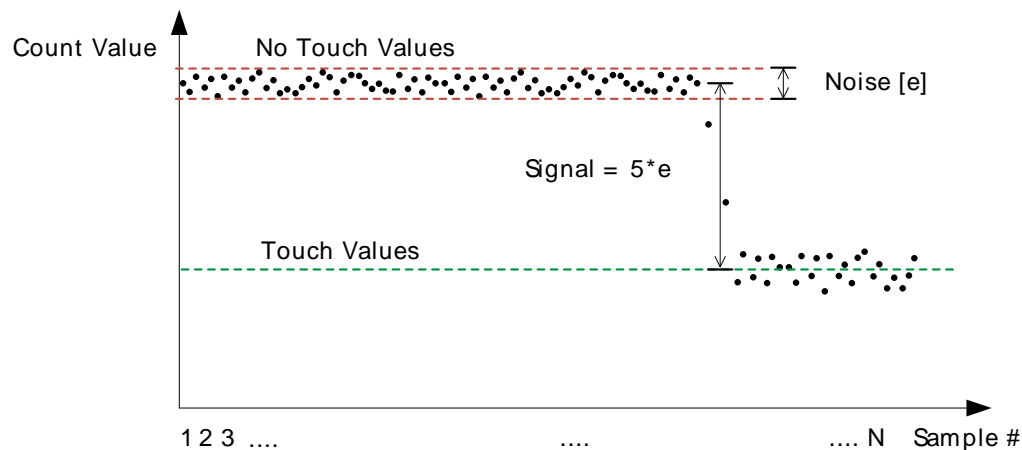

2.3 External Disturbances

External disturbances and environmental changes that can affect either the actual capacitance of a sensor or a change in the measured capacitance are listed below. Some of these can be dealt with by improving the hardware design (marked "hardware"). Some are inherent with the working principle of the capacitance measurement and should be handled by software (marked "software").

- Radiated and conducted noise from other components, traces and power supply. (Hardware)
- Changes or noise in supply voltage. (Software/Hardware)
- Changes in temperature. (Software)
- Changes in humidity. (Software)
- Jitter in the low frequency (LF) oscillator frequency. (Hardware)

This document focuses on minimizing the hardware related disturbances. The ones marked software is discussed in the capacitive touch software application note (AN0028).

3 Sensor Design

How the actual touch pads and printed circuit board are designed has a significant impact on the performance of the capacitive touch solution. Parameters such as size and shape of the pads and how the signals are routed affects the signal integrity. The following section discusses what affects performance and best design practices.

3.1 Touch Buttons

For simple touch buttons there is mainly one parameter of the pad itself that matters the most; size. The shape and how far apart the pads are placed should also be considered to minimize false detection on neighboring pads.

3.1.1 Button Shape

A round button is best, but other shapes works as well. The corners should be rounded as much as possible, this will minimize stray field lines and focus the strongest field right above the button itself. See Figure 3.1 (p. 6) for an illustration of the touch button parameters; D - Diameter/Size, S - Spacing and ground clearance. The partly covering hatched ground and ground clearance are explained further in Section 4.1.2 (p. 10) .

Figure 3.1. Simple Button Design

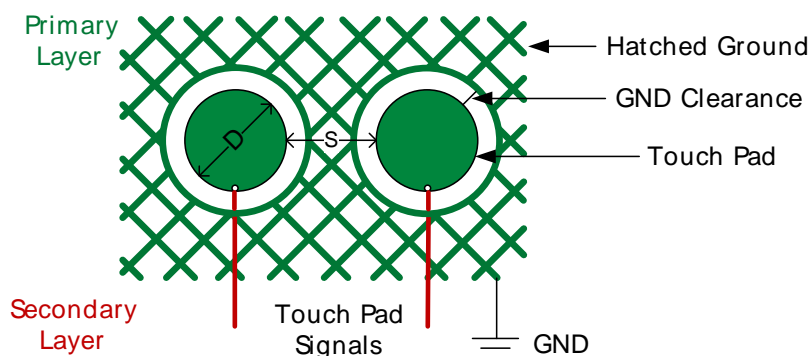

3.1.2 Button Size

The size of the buttons should be similar to the footprint of a touching finger. For circular pads this equates to a diameter of approximately 15 mm. Any diameter between 10 mm and 20 mm is fine. The exception to this would be proximity sensing and sensing through thick overlays. To increase the strength of the field further away from the surface of the overlay, the pad can be made larger. For an illustration of how the pad size affects SNR through different overlay thicknesses, see Figure 4.2 (p. 11) .

3.1.3 Spacing

It is important that the touch pads are spaced far enough apart so that a touch does not also trigger neighboring pads. This can be handled by software as well, because almost always, one of the pads will have the strongest signal.

The spacing is also dependent on the thickness of the overlay. For thin overlays the signal will in general be much stronger on the touched pad than the neighboring pads compared to thicker overlays. As a general rule, the spacing between the border of two pads should be equal to or greater than the overlay thickness.

3.2 Sliders

For sliders, the most significant difference from buttons is that two or more pads will be affected by a single touching finger at the same time. In practice this means that the pads are placed closer together and software interprets the finger's position by interpolating measurements from several pads.

3.2.1 Simple Slider

A simple slider can be implemented as illustrated in Figure 3.2 (p. 7). The slider has 5 pads which are spaced close together with an interleaving design. The interleaving allows for a linear transition in measured capacitance on the different pads when a finger is moved from one side to the other. The actual position is deduced by software from the measurements on the different pads.

Figure 3.2. Simple Slider Design



High resolution, high pin count

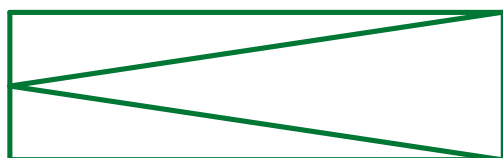

Low resolution, low pin count

3.2.2 Duplexed Slider

If a longer slider with more pads is desired, but the amount of capacitive touch pins from the MCU is limited, a duplexed slider can be used. The requirement is that only one finger is expected to touch the slider at any moment in time. By connecting two and two pads together as shown in Figure 3.3 (p. 8), software can deduce which pad was actually touched by finding the pad which also has neighboring pads with an increased capacitance.

Figure 3.3. Duplexed Slider Design

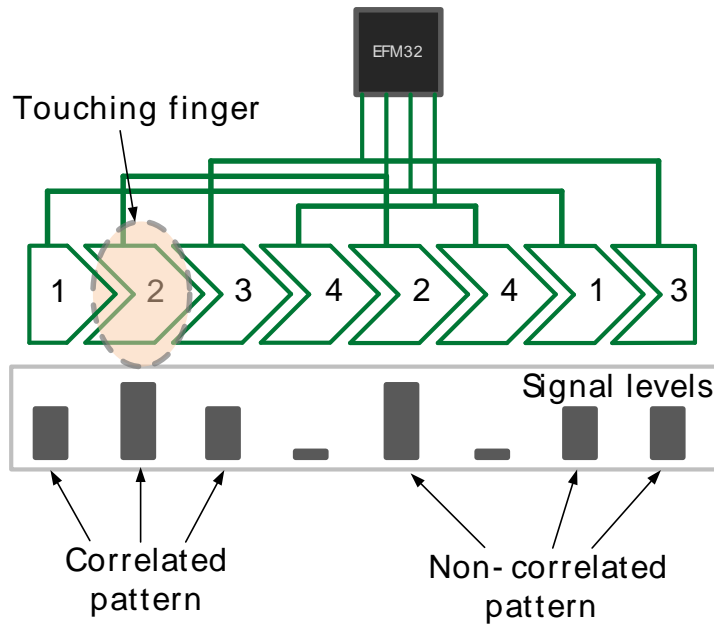

3.2.3 Radial Slider

Both the simple and duplexed slider can be turned into a radial slider by connecting the two ends together as shown in Figure 3.4 (p. 8) .

Figure 3.4. Radial Slider Design

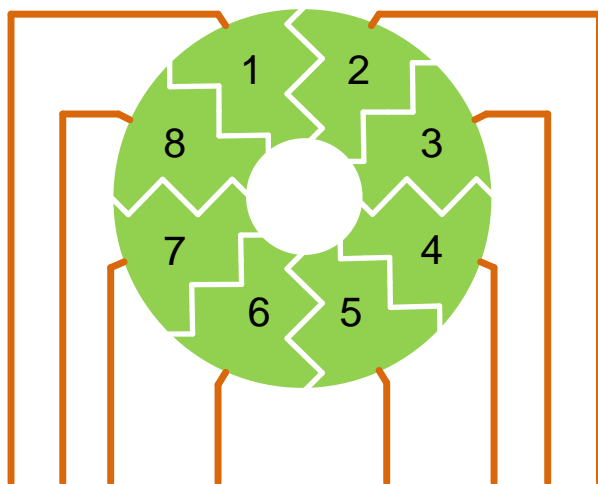

3.3 Two Dimensional Touch Arrays

The same principle as the duplexed slider can be utilized to make two dimensional keypads or similar designs. The limitation with one finger at a time applies here as well. An example of a 12 keyed keypad is illustrated in Figure 3.5 (p. 9). Software needs to handle the translation between which different pins are touched and which key that has actually been touched.

Figure 3.5. Two Dimensional Matrix Keypad

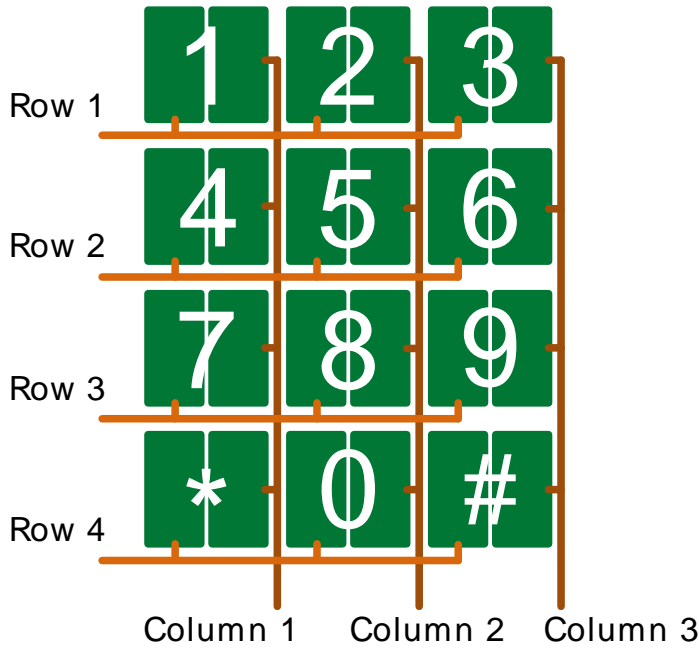

3.4 Proximity Sensing

Proximity detection can be accomplished by making a much larger pad, or a ring around smaller buttons/sliders. The larger area will set up a stronger electric field, extending further from the device than the field from small buttons/sliders does. The limitation is that a larger body of "virtual ground" is needed to affect the capacitance. This is fine for most applications since the proximity detection is supposed to detect the presence or closeness of a hand, foot or similar. Figure 3.6 (p. 9) illustrates how a proximity ring can be implemented around normal touch buttons.

Figure 3.6. Proximity Sensing Pad

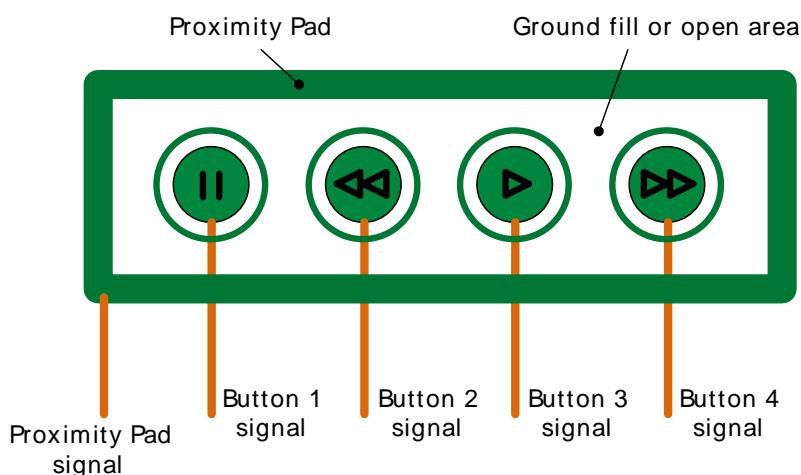

4 Capacitive Touch Product Design

4.1 PCB Design

Regardless of the different button/slider designs there are a few PCB design guidelines to get the best possible SNR which applies to them all.

4.1.1 Signal Integrity

To minimize radiated noise from other components and traces on the PCB, the touch traces should be kept away from other signals and as short as possible. This means that if possible, no other signals or components should be routed through the touch-area of the PCB. This applies to all layers of the PCB.

If other traces must be placed through the touch area they should be kept as far away from the touch pad and touch traces as possible. They should cross perpendicular to the touch traces and not routed alongside, parallel to any touch traces.

The touch traces should be taken down to the secondary side of the PCB at the edge of the touch pad to get them as far away as possible from the touch surface. This will ensure that a touching finger only affects the actual pads and not the traces.

The traces should be kept thin, 0.2 mm for example, and not placed too close together in order to avoid that they affect each other. The EFM32 senses capacitance on different channels sequentially, so the chance of the touch traces affecting each other should be minimal. A spacing of 0.5 mm is sufficient, the most important thing is to keep the traces short and away from noise sources.

4.1.2 Ground

How much and how close the touch pads are to the ground pour affects the nominal capacitance. A large nominal capacitance gives high resistance against noise but the change in capacitance introduced by a finger nearby is also reduced. To keep the nominal capacitance relatively low, the ground pour should be hatched. A fill percentage of 10-40% is fine when overlay thickness is less than 4 mm. For thicker overlays, a less dense ground layer will result in less nominal capacitance and better response upon touch (3-15% fill).

The ground pour should be on the same side as the pads with a few millimeters clearance to the pads (1.5 mm - 4 mm). See Figure 3.1 (p. 6) for an illustration of simple buttons with ground pour.

If protection against touches from the secondary side is needed, the secondary side should be filled with ground pour which acts as shielding. This added shield will increase the nominal capacitance which decreases sensitivity and SNR, again the fill ratio of the shield can be reduced to affect the nominal capacitance less, but this will also reduce the effectiveness of the shield. For a 10 mm button, the achievable overlay thickness is decreased with approximately 3 millimeters with the secondary side shielded by a 100% filled ground layer. See Figure 4.1 (p. 11) for a comparison of SNR between ground shield and no ground shield on the secondary side.

Figure 4.1. SNR affected by ground shield

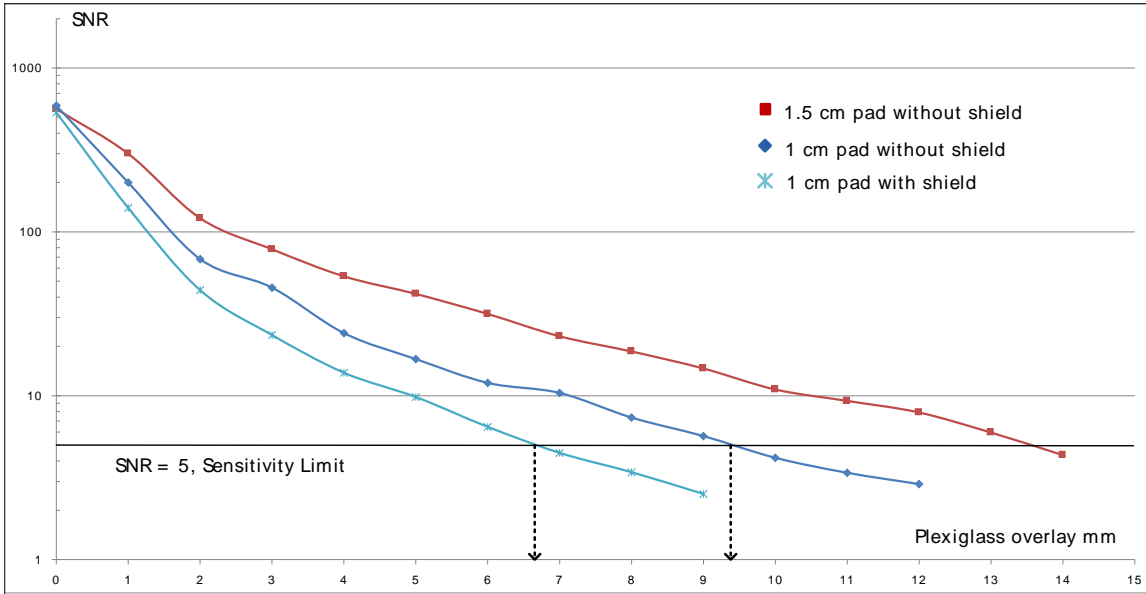

4.2 Overlay

Since a capacitive touch button is actually a capacitor where a human finger acts as one of the plates, the distance and dielectric constant of the material between the touch pad and the human finger determines the capacitance. The shorter the distance and the higher the dielectric constant, the higher the capacitance. To reduce noise and possibly false touches on neighboring pads, it is important that the overlay does not flex when a finger touches the surface. The overlay should be glued or clamped to the PCB so that they do not move relative to each other upon touch or other external forces.

4.2.1 Overlay Thickness

The thickness of the overlay is directly affecting the SNR that can be achieved for a given touch solution. Figure 4.2 (p. 11) shows the SNR achievable for different overlay thicknesses and button sizes with Plexiglas as overlay material.

Figure 4.2. SNR affected by button pad size

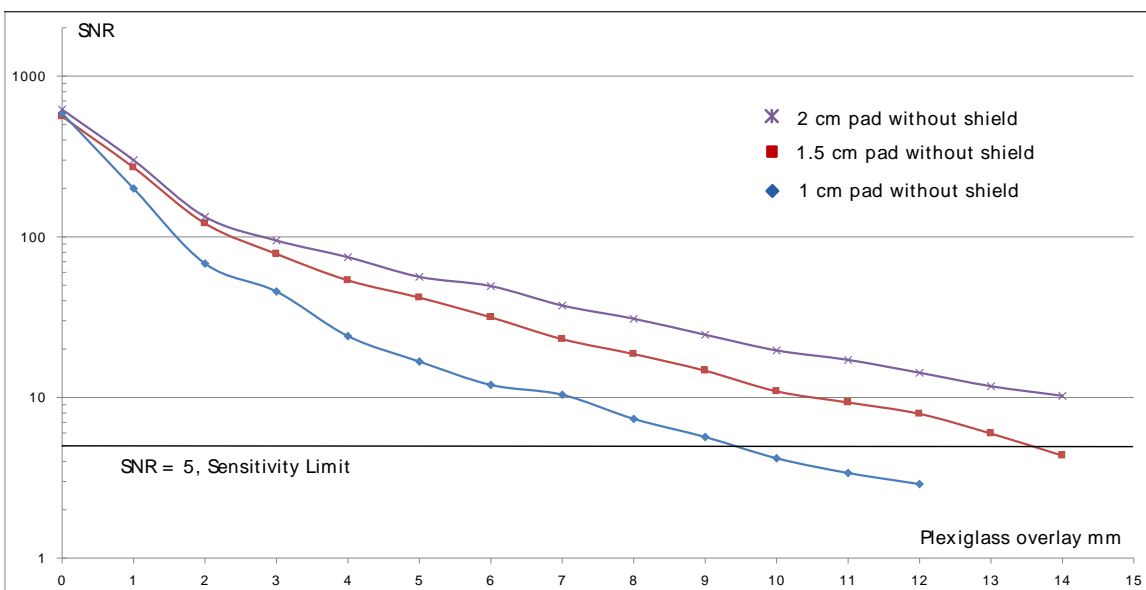

4.2.2 Overlay Material

Two typical materials used for overlays are glass or acrylic. Of these two, glass has the highest dielectric constant and is therefore the "best" overlay material of these two. Higher dielectric constant for the overlay material results in a stronger electric field further from the metal pad. Almost all of the most common overlay materials are better than air, therefore the amount of air between the metal pad and the overlay should be minimized. See Table 4.1 (p. 12) for a listing of the dielectric constant for common overlay materials.

For fixing the overlay in place on top of the touch PCB a proper adhesive or clamping solution should be implemented. An example of an acrylic bonding product is the 200MP series from 3M. Many other products exist for different overlay materials. The important thing is to minimize the air-gap and distance as much as possible.

Table 4.1. Dielectric constants of typical materials used in front panels

Material	Dielectric Constant
Air	1
Paper	3.8
Glass	3.7 - 10
Water	80
Plexiglas	2.6 - 3.5
Polyimide	3.4
Polyethylene	2.2
Polystyrene	2.4 - 2.7
Polyethylene terephthalate (PET)	3.7
FR4 (fiberglass reinforced epoxy)	4.2
PMMA (Poly methyl methacrylate), acrylic plastic	2.6 - 4
Bonding adhesive, for example 3M 467MP/468MP	2 - 3

4.3 Curved Touch Surface

For curved touch surfaces two simple options are described here, either a flexible PCB or implementing a metal spring to get the touch pad as close as possible to the users finger.

4.3.1 Flex-PCB

The capacitive touch pads can be implemented on a flexible PCB. The connection between the main PCB and the flex-pcb with the buttons will also be touch sensitive. The construction should be kept stable and away from noise sources. This solution is illustrated in Figure 4.3 (p. 13) .

Figure 4.3. Flexible PCB for Curved Surfaces

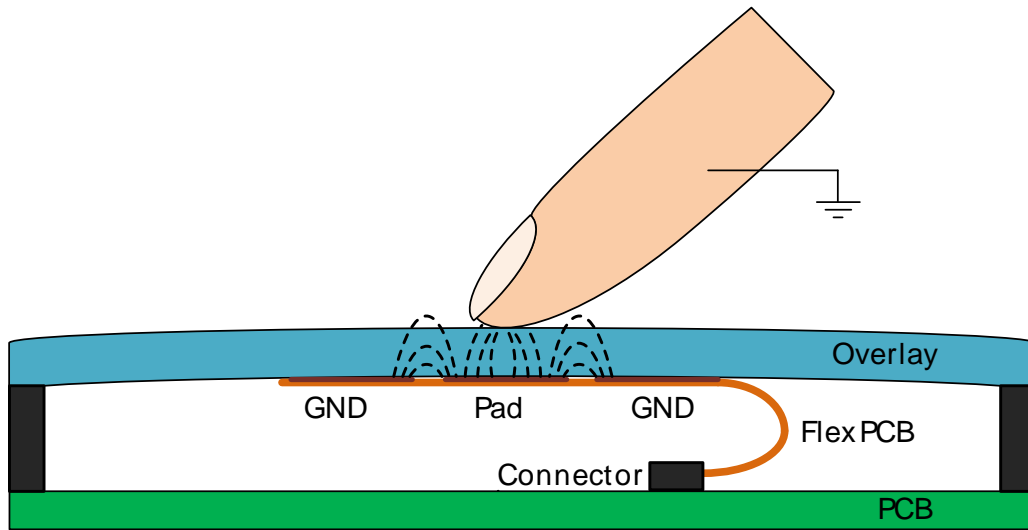

4.3.2 Spring to Surface

Another option to get the touch pad closer to the surface is to use metal springs between the PCB and the underside of the top surface. This is illustrated in Figure 4.4 (p. 13) .

Figure 4.4. Spring to Surface Solution

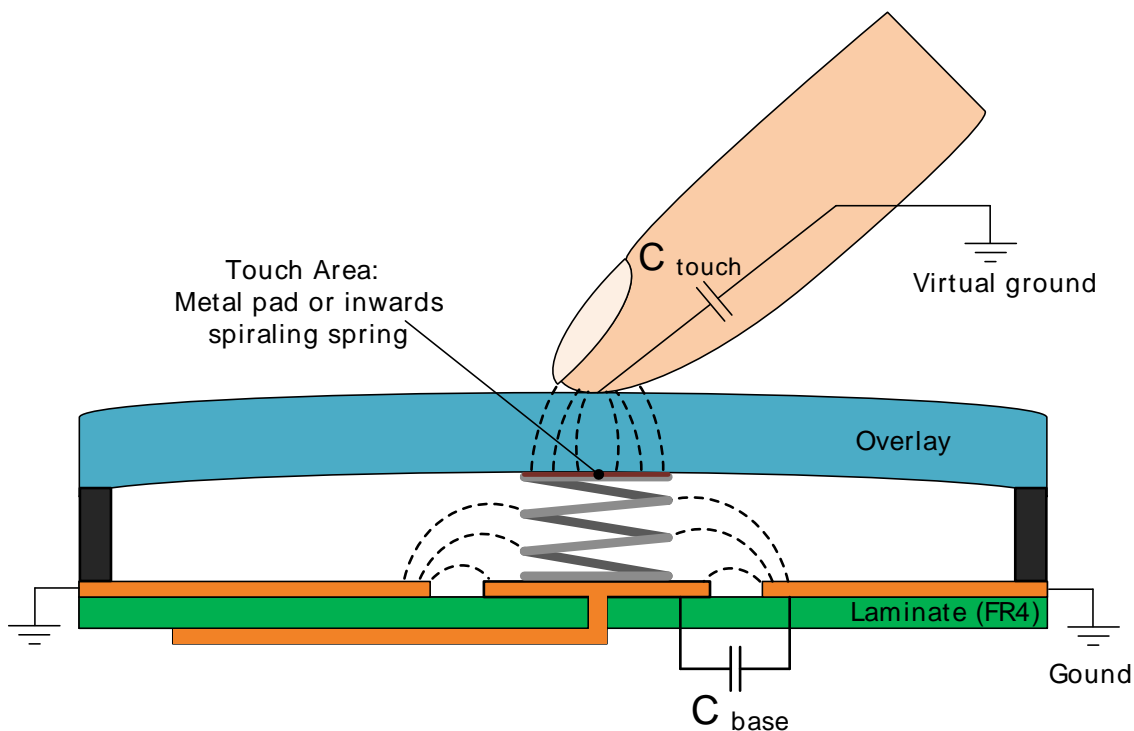

4.4 Other Considerations

4.4.1 Oscillator

The accuracy of the RC relaxation oscillator solution used by the EFM32 to sense capacitance is dependent on a stable clock reference for the capture window. Therefore it is highly recommended

to implement a low frequency crystal oscillator (LFXO) when implementing capacitive touch with the EFM32. The SNR achievable with a crystal oscillator is around 30 times better than the SNR achieved with the internal low frequency RC oscillator clock source.

4.4.2 Electrostatic Discharge Protection

Usually the combination of a PCB soldermask layer or overlay between the metal pads and a touching finger, and internal protection diodes in the MCU, is sufficient as ESD protection for the microcontrollers capacitive touch pins. If a user can come in contact with the metal-pads directly, some added protection should be considered. A series resistor of 100 Ohm - 1 kOhm in combination with external ESD-protection diodes as illustrated in Figure 4.5 (p. 14), will not affect the capacitive touch performance significantly.

Figure 4.5. Optional Electrostatic Discharge Protection

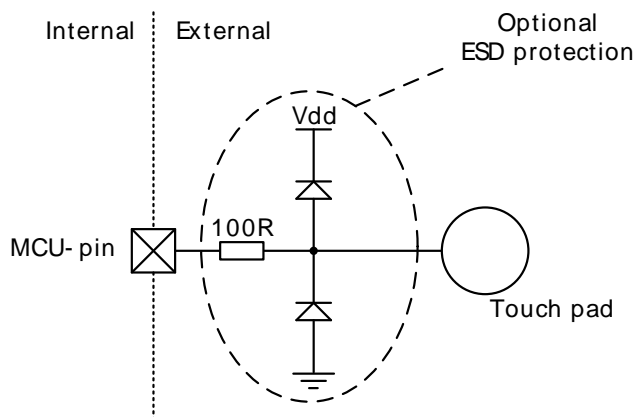

5 Summary

Hardware design for capacitive touch can involve a range of conflicting design requirements. This document includes some guidelines and ideas which should be considered when deciding between the many trade-offs during product development. The most important tips regarding PCB layout for capacitive touch is listed in the following table.

- Include an external low frequency crystal in the design.
- Less ground and larger pads makes a thicker overlay possible.
- Route the touch traces as short and clean as possible. Keep them clear of noisy signals and components.

The included zip file with a pcb-design for a tiny gecko device demonstrates how these rules can successfully be followed in a two-layer design.

Note

Remember that proper software calibration is required regardless of the PCB layout and product design.

6 Revision History

6.1 Revision 1.02

2013-09-03

New cover layout

6.2 Revision 1.01

2012-11-12

Added capacitive touch PCB design files.

6.3 Revision 1.00

2012-03-07

Initial revision.

A Disclaimer and Trademarks

A.1 Disclaimer

Silicon Laboratories intends to provide customers with the latest, accurate, and in-depth documentation of all peripherals and modules available for system and software implementers using or intending to use the Silicon Laboratories products. Characterization data, available modules and peripherals, memory sizes and memory addresses refer to each specific device, and "Typical" parameters provided can and do vary in different applications. Application examples described herein are for illustrative purposes only. Silicon Laboratories reserves the right to make changes without further notice and limitation to product information, specifications, and descriptions herein, and does not give warranties as to the accuracy or completeness of the included information. Silicon Laboratories shall have no liability for the consequences of use of the information supplied herein. This document does not imply or express copyright licenses granted hereunder to design or fabricate any integrated circuits. The products must not be used within any Life Support System without the specific written consent of Silicon Laboratories. A "Life Support System" is any product or system intended to support or sustain life and/or health, which, if it fails, can be reasonably expected to result in significant personal injury or death. Silicon Laboratories products are generally not intended for military applications. Silicon Laboratories products shall under no circumstances be used in weapons of mass destruction including (but not limited to) nuclear, biological or chemical weapons, or missiles capable of delivering such weapons.

A.2 Trademark Information

Silicon Laboratories Inc., Silicon Laboratories, the Silicon Labs logo, Energy Micro, EFM, EFM32, EFR, logo and combinations thereof, and others are the registered trademarks or trademarks of Silicon Laboratories Inc. ARM, CORTEX, Cortex-M3 and THUMB are trademarks or registered trademarks of ARM Holdings. Keil is a registered trademark of ARM Limited. All other products or brand names mentioned herein are trademarks of their respective holders.

B Contact Information

Silicon Laboratories Inc.

400 West Cesar Chavez

Austin, TX 78701

Please visit the Silicon Labs Technical Support web page:

<http://www.silabs.com/support/pages/contacttechnicalsupport.aspx>

and register to submit a technical support request.

Table of Contents

1. Introduction	2
2. Capacitive Sensing Basics	3
2.1. Working Principle	3
2.2. Signal-to-Noise Ratio	4
2.3. External Disturbances	5
3. Sensor Design	6
3.1. Touch Buttons	6
3.2. Sliders	7
3.3. Two Dimensional Touch Arrays	8
3.4. Proximity Sensing	9
4. Capacitive Touch Product Design	10
4.1. PCB Design	10
4.2. Overlay	11
4.3. Curved Touch Surface	12
4.4. Other Considerations	13
5. Summary	15
6. Revision History	16
6.1. Revision 1.02	16
6.2. Revision 1.01	16
6.3. Revision 1.00	16
A. Disclaimer and Trademarks	17
A.1. Disclaimer	17
A.2. Trademark Information	17
B. Contact Information	18
B.1.	18

List of Figures

2.1. Capacitive Sense Overview	3
2.2. Analog comparator RC relaxation oscillator	4
2.3. Signal to noise ratio	5
3.1. Simple Button Design	6
3.2. Simple Slider Design	7
3.3. Duplexed Slider Design	8
3.4. Radial Slider Design	8
3.5. Two Dimensional Matrix Keypad	9
3.6. Proximity Sensing Pad	9
4.1. SNR affected by ground shield	11
4.2. SNR affected by button pad size	11
4.3. Flexible PCB for Curved Surfaces	13
4.4. Spring to Surface Solution	13
4.5. Optional Electrostatic Discharge Protection	14

List of Tables

4.1. Dielectric constants of typical materials used in front panels 12

silabs.com

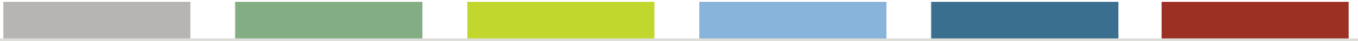

ZERO
ARM Cortex-M0+

TINY
ARM Cortex-M3

GECKO
ARM Cortex-M3

LEOPARD
ARM Cortex-M3

GIANT
ARM Cortex-M3

WONDER
ARM Cortex-M4